

Influence of a new chemical crosslink system on the morphology and crystallite size of nylon-12

H. G. BADER, H. F. E. SCHNELL, D. GÖRITZ

Institute of Applied Physics, University of Regensburg, Universitätstrasse 31, 8400 Regensburg, Germany

U.-R. HEINRICH

Institute of Macromolecular Chemistry, University of Freiburg Hermann-Staudinger-Haus, Stefan-Meier-Strasse 31, 7800 Freiburg, Germany

H.-J. SCHULTZE

EMS Chemie AG, 7013 Domat/Ems, Switzerland

Special polyamide chains of desirable structure were polymerized such that they already contained reactive sites at the chain ends. The degree of crosslinking is determined by the chain structure and the amount of a specific epoxide silane, which causes crosslinking by formation of condensed silicon centres. The influence of the chain structure and the amount of epoxide silane on the morphology and the crystallite size were investigated by transmission electron microscopy using electron spectroscopic imaging and differential scanning calorimetry. A three-component structure was observed, consisting of crystalline and amorphous regions with a transition region between them. The lamellar thickness of the crystallites (5–7 nm) was independent of the chain structure and of the amount of epoxide silane, i.e. independent of the degree of crosslinking. Conversely, the lamellar length of the crystallites was dependent on the chain structure. For the material containing linear chains it was usually greater than 100 nm; for the material containing highly branched chains it varied from about 100 nm down to a block-like structure. The width of the transition region, in which the chains are under stress, was about 2 nm. The condensed silicon centres (crosslink points) were randomly distributed with respect to the resolution of the transmission electron microscope. RuO_4 is a good staining agent for nylon-12.

1. Introduction

Aliphatic polyamides (nylons) are partially crystalline thermoplastics. The various types of nylon in use differ from each other in the ratio and position of amide groups (CONH) with respect to CH_2 groups in the linear macromolecular chains. Independent of this ratio, they show characteristics that make them of interest for many technical applications.

The creep behaviour under constant stress of nylons is good with respect to other thermoplastics, but intermolecular interactions are not strong enough to prevent chain-sliding caused by an applied stress. The material flows and changes its geometrical form. One way to improve the creep behaviour is to crosslink the polymer chains [1].

Schnell *et al.* [2] determined the influence of the degree of crosslinking on the mechanical behaviour, especially the stress–strain curve, over a wide range of temperatures and strain rates.

The influence of the chain structure and the amount

of epoxide silane, i.e. the degree of crosslinking, on the morphology and crystallite size is investigated.

2. New chemical crosslink system for aliphatic polyamides

Processes to crosslink thermoplastic materials, mainly olefines such as polyethylene, are well known and can be divided into radiation and chemical crosslinking. In both cases crosslinking occurs statistically in the polymer structure and is accompanied by the breaking of existing bonds and/or by secondary reactions. Consequences are, for example, discolourations and a bad influence on the electrical properties.

The new crosslink system, developed by the research department of EMS-Chemie AG, avoids these negative aspects. Ideally it can be outlined in two reaction steps. First, the polymerization of special polyamide chains. The application of linear and branched monomers leads to chains of desirable structure,

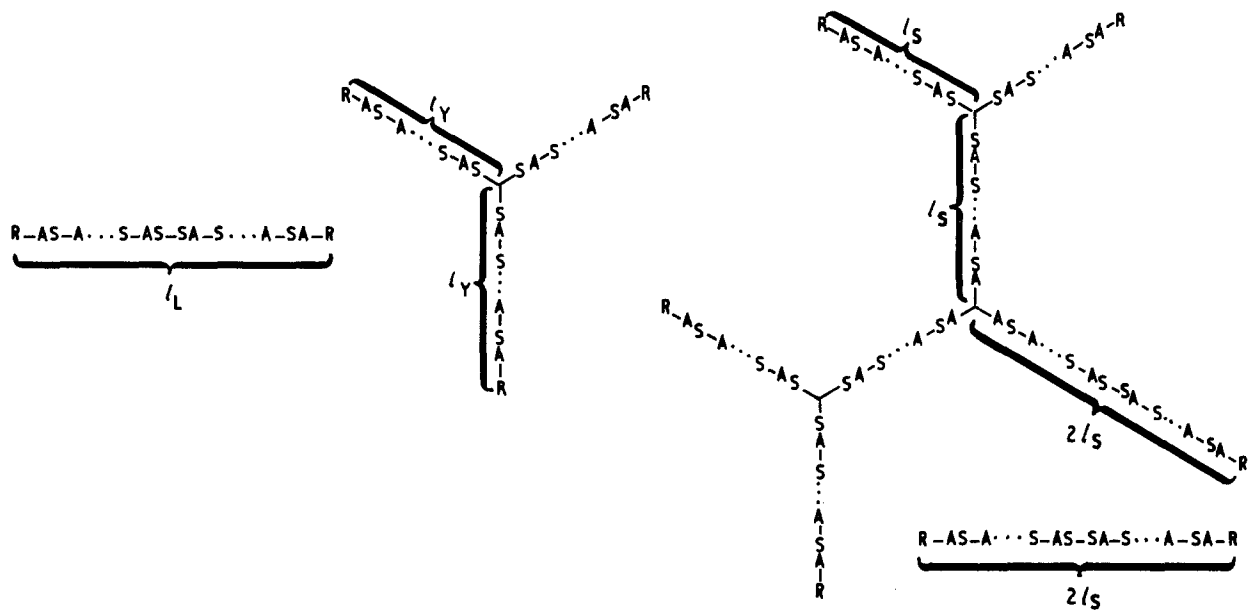

Figure 1 Desirable chain structures containing reactive sites at the chain ends: linear (L), simply branched (Y) and highly branched (S) consisting of 18/46 linear and 28/46 highly branched chains. Shortest linear chain segments: $l_L = 260$ nm, $l_Y = 85$ nm and $l_S = 28$ nm. A, Amino-group; S, carboxyl-group; and R, reactive site.

which contain reactive sites at the chain ends. The chain structure is dependent on the types of monomers and on the ratio of the number of linear and branched monomers (Fig. 1). Secondly, the crosslinking caused by epoxide silane molecules. The molten charge of chains is thoroughly mixed during shaping (injection or extrusion moulding) with epoxide silane. The epoxide silane contains two reactive sites. One, the epoxide site, reacts spontaneously with the reactive site at the chain ends. The other, the silane site, reacts by contact with water with another silane site by condensation to $-\text{Si}-\text{O}-\text{Si}-$ bridges. In the case of too few epoxide silane molecules there will mainly be a lengthening of the nylon chains (Fig. 2). Excess epoxide silane molecules leads to multifunctional, condensed silicon centres and forms a network (Fig. 3). Therefore, both the chain structure and the amount of epoxide silane in the material determine the degree of crosslinking.

3. Experimental procedure

3.1. Materials

The experimental materials used were nylon-12 with three different chain structures and with various amounts of epoxide silane. Specimens were formed by injection moulding at about 250°C . After injection moulding, the specimens were annealed in an oxygen-free atmosphere for 1 h at 300°C , to ensure that molecular orientation, caused by injection moulding, was removed. After annealing, the crosslinking process was activated by storing the specimens in water at 60°C (above the glass transition temperature of about 50°C) for 3 days. Specimens were subsequently dried in a vacuum oven at 90°C for 14 h and kept in a desiccator, to eliminate the influence of water.

The specimens were stained with ruthenium tetroxide (RuO_4) for 1 h using a solution of 0.2 g ruthenium trichloride in 10 ml 5.25% aqueous sodium hypo-

chloride [3]. Subsequently the sectioning was done with an ultramicrotome (Reichert-Jung Ultracut E). As the glass transition temperature of nylon-12 is about 50°C , the samples could be sectioned at room temperature with a diamond knife. The estimated thickness of the obtained ultrathin sections was 30–50 nm. Specimens with three different chain structures and various amounts of epoxide silane were investigated as shown in Table I. 100% epoxide silane means that the number of epoxide silane molecules is equal to the number of reactive sites at the chain ends.

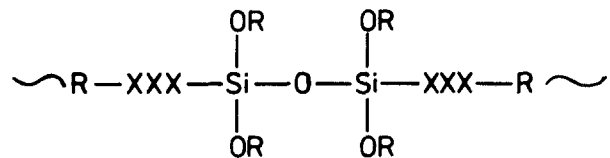

Figure 2 Few epoxide silane: chain lengthening by $-\text{Si}-\text{O}-\text{Si}-$ bridges.

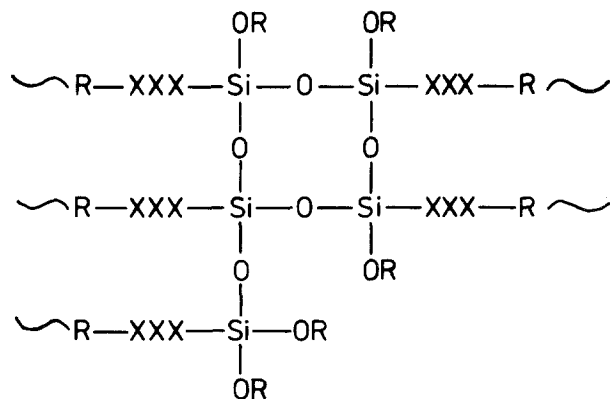

Figure 3 Excess epoxide silane: multifunctional netpoint by condensed silicon centres.

TABLE I Chain structure, content of epoxide silane, average molecular weight (Equation 1), average chain length (Equation 2), shortest linear chain segment (Fig. 1) and codes of investigated materials

Code	Chain structure	Epoxide silane (%)	Average molecular weight (g mol ⁻¹)	Average chain length (nm)	Shortest linear chain segment, l_L, l_Y, l_S (nm)
L0	Linear	0	30 500	260	260
L100	Linear	100			
Y0	Simply branched	0	30 000	255	85
Y100	Simply branched	100			
S0	Highly branched	0	18 800	160	28
S100	Highly branched	100			

The average molecular weight and the average chain length characterize the desirable chain before crosslinking. The shortest linear chain segment of one chain structure characterizes the shortest possible length occurring between chain ends and/or branching points (see Fig. 1).

Three types of chain structure were investigated: linear (L), simply branched (Y) and highly branched (S). For example, the code L100 refers to the material containing linear chains and 100% epoxide silane molecules with respect to the number of reactive sites at the chain ends.

The number of reactive sites, n_r , and the number of unreactive sites, n_u , at the chain ends were determined by an acid–base titration method. This corresponds to the average molecular weight, M . For example, for the L-material we can calculate M_L as

$$M_L = \frac{1}{(n_r + n_u)/2} = \frac{2}{(58.5 + 7.0) \mu\text{mol/g}} \approx 30\,500 \text{ g mol}^{-1} \quad (1)$$

The average chain length, l_L , of the L-material can be calculated as

$$l_L = \frac{M_L}{M_{\text{Mon}}} l_{\text{Mon}} \quad (2)$$

where $M_{\text{Mon}} = 197.2 \text{ g mol}^{-1}$ and $l_{\text{Mon}} = 1.672 \text{ nm}$ are, respectively, the molecular weight and the length of a nylon-12 monomer unit.

For the case when every chain is involved in the network, one chain before crosslinking is equal to a “network chain” after crosslinking. This means that the “network chain molecular weight”, $M_{n,L}$, for the ideal network without imperfections is equal to the molecular weight, M_L , of the chains before crosslinking. The greatest number, $n_{L,\text{max}}$, of network chains per unit volume for the L-material can be calculated as

$$n_{L,\text{max}} = (N_A/M_{n,L})\rho \approx 2 \times 10^{19} \text{ cm}^{-3} \quad (3)$$

where N_A is Avogadro’s number and ρ is the density of nylon-12. The density was found to be 1.024 g cm^{-3} , independent of the chain structure and the amount of epoxide silane, by using a density gradient column containing n-heptane and carbon tetrachloride as the flotation liquid. Analogous calculations yield the aver-

age molecular weight, the average chain length and the shortest part of a chain for the Y- and S-material.

3.2. Equipment

All of the transmission electron microscopy (TEM) micrographs were recorded with a Zeiss EM 902 which was described in detail in References 4 and 5. The extraordinary resolution of this TEM is achieved by an integrated prism–mirror–prism spectrometer which provides mostly electrons of identical energy so that chromatic aberration and the scattering background are very much reduced (electron spectroscopic imaging, ESI). In addition, this spectrometer allows the use of the inelastically scattered electrons for image generation. With this kind of imaging further information about the local concentrations of specific elements can be obtained.

Differential scanning calorimetry (DSC) measurements were carried out using a Perkin–Elmer DSC 2 differential scanning calorimeter under nitrogen. A heating rate of 10 K min^{-1} was adopted and the samples were placed in standard aluminium pans. The accuracy of the temperature was $\pm 1 \text{ K}$.

4. Results and discussion

4.1. TEM

In Fig. 4 an unstained (Fig. 4a) and a stained (Fig. 4b) ultrathin section of the L0-sample is shown. To obtain adequate resolution, the investigated ultrathin cuts had a thickness of about 30–50 nm. With such samples the achieved electron scattering contrast between the crystalline and amorphous phase based on different densities is far too weak. Therefore, no structure can be observed in Fig. 4a. By staining with the strongly oxidizing RuO_4 some areas are sharply marked because the ruthenium atoms are mostly gathered there. This causes a high degree of electron scattering in these areas (Fig. 4b), so that the staining ability of RuO_4 , which was predicted by Trent *et al.* [6] for all polymers containing amides, is clearly shown for nylon-12.

Fig. 5a to f show elastic bright-field electron micrographs of the investigated samples L0 to S100. In every micrograph unstained parts are observed which are surrounded by parallel-running very thin and

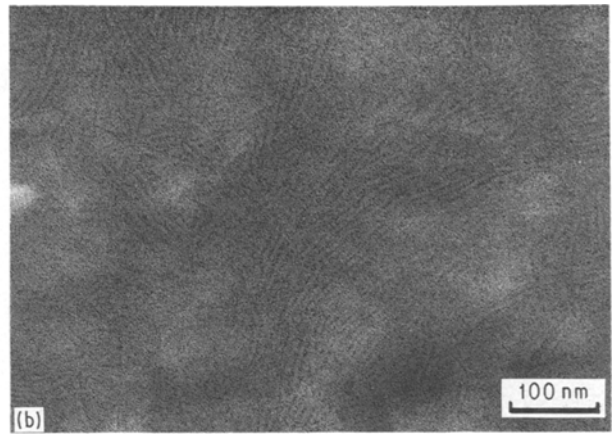
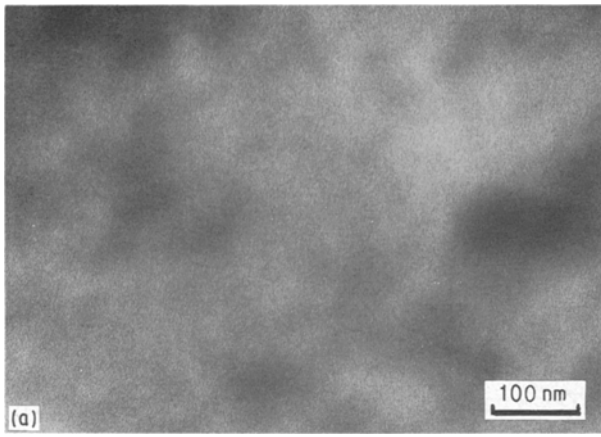

Figure 4 Elastic bright-field electron micrographs of linear nylon-12 without epoxide silane (L0): (a) unstained ultrathin cut and (b) stained ultrathin cut.

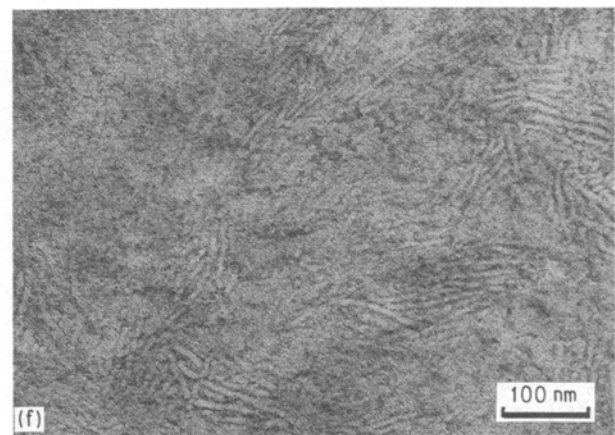
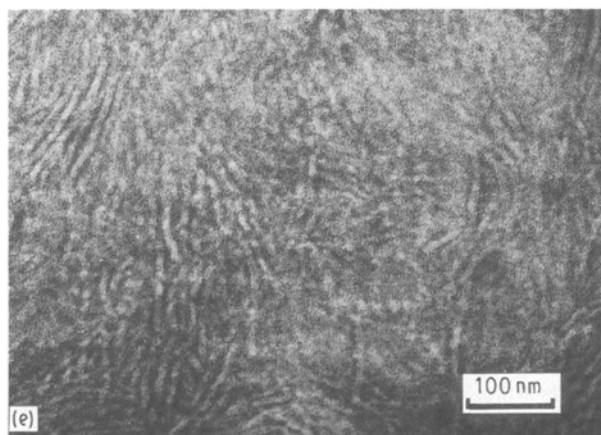
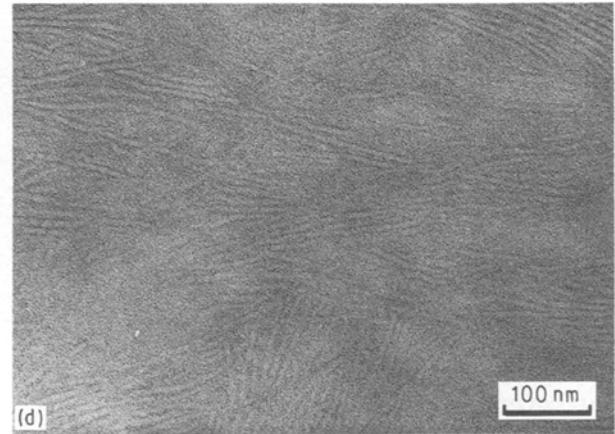
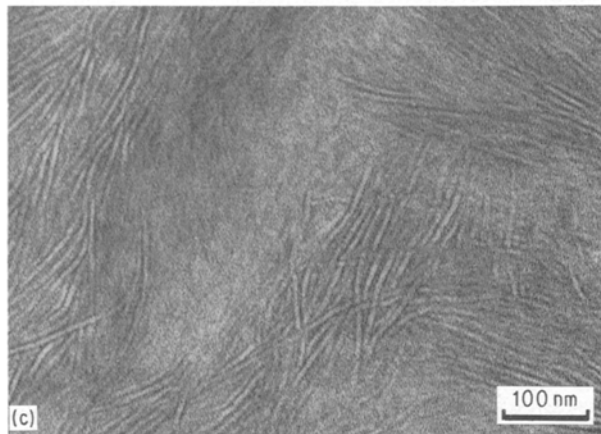
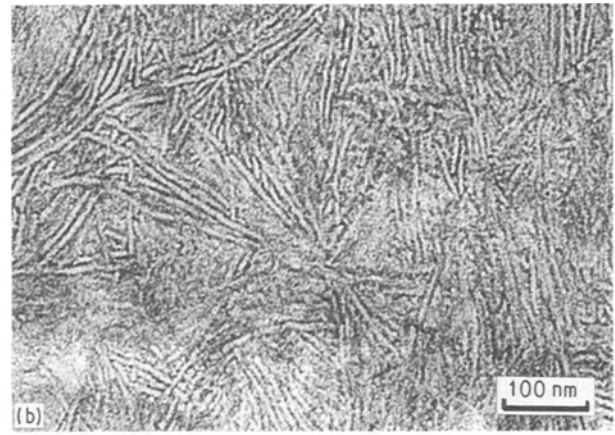
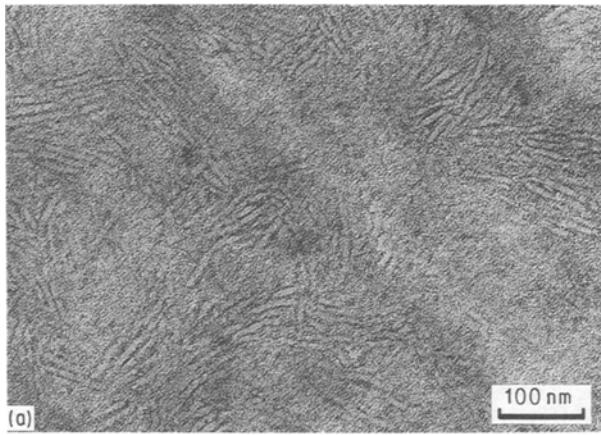

Figure 5 Elastic bright-field electron micrographs of the investigated materials: (a) stained ultrathin cut of L0, (b) stained ultrathin cut of L100, (c) stained ultrathin cut of Y0, (d) stained ultrathin cut of Y100, (e) stained ultrathin cut of S0 and (f) stained ultrathin cut of S100.

highly stained regions. This is typical for semicrystalline polymers whose crystalline phase is based on a lamellar structure. Between the highly stained regions the crystalline phase is clearly outlined in every micrograph. In addition, the selective staining only along the crystalline lamellae indicates the existence of a transition region lying between the crystalline and amorphous phases. For other semicrystalline polymers and staining agents the existence of such a transition region besides the crystalline and amorphous phases has previously been reported by Kanig [7] and Kunz *et al.* [8]. The chemical interaction of RuO₄ with the chain molecules and the selective staining is still not understood well. A possible explanation for the selective staining is given by Kunz *et al.* [8] on assuming that the chains in the transition region are highly strained, which results in a higher Gibbs energy and thus in a higher reactivity against oxidizing agents.

When viewing Fig. 5a to f, no overall orientation can be detected. This is consistent with wide-angle X-ray scattering (WAXS) experiments, so the crystallization of the investigated samples is proved to be isotropic. The lamellar thickness was determined to be about 5–7 nm regardless of the amount of epoxide silane or chain structure, i.e. the degree of crosslinking. This result is comparable with those reported by Wunderlich [9] for other nylons, and represents generally the lower limit of a stable lamellar structure so far known. The thickness of the highly stained transition region was about 2 nm. This value corresponds closely to those reported by Flory *et al.* [10] (1.0–1.2 nm) based on theoretical calculations, as well as by Mandelkern *et al.* [11] who reported values of 1.3–3.3 nm for linear polyethylene, depending on the molecular weight of their samples.

The micrographs for the L- and Y-materials show no significant differences. The length of the shortest linear chain segment (see Table I) is much greater than the observed lamellar thickness. Therefore, there are only minimum restrictions on chain-folding and crystalline growth regardless of the degree of crosslinking, i.e. a well-developed lamellar structure can be formed. Contrary to this, the micrographs for the S-material and especially that showing the S100 sample, show a more disturbed crystalline phase. Apart from long ordered single lamellae, where the staining indicates some irregularities already by showing these lamellae to be more curved, shorter lamellae and small block-like crystals are detected. For the S-material the length of the shortest linear chain segment is only 28 nm (see Table I), which is not more than about five times the thickness of the observed lamellae. In addition, this chain structure is highly branched so that a parallel lining-up of neighbouring chains is more difficult to achieve than for the less complex L- and Y-materials. These two reasons are responsible for a much more restrictive crystal growth.

For additional insight into the crosslinking process and especially the distribution of the condensed silicon centres, only electrons inelastically scattered from silicon atoms were used for image generation. As the S100 sample has the highest number of reactive sites

and therefore contains the greatest amount of epoxide silane molecules, it was expected to be the best for studying the chemical crosslinking procedure.

Fig. 6 shows the net element distribution of silicon in an S100 sample, which was obtained by using the silicon $L_{2,3}$ ionization edge. This edge is located at 99.2 eV in the electron loss spectrum of inelastically scattered electrons. For the net distribution a micrograph was taken right below the $L_{2,3}$ -edge with an energy loss compensation of $\Delta E = 90$ eV, digitized and subtracted from one taken just above this edge at $\Delta E = 110$ eV.

The micrograph shows a diffuse “salt-and-pepper” structure, which is obtained whenever the inelastic scattering intensity of the element of interest is too weak for clear detection. With respect to the detection limit of the TEM for silicon in the investigated material, a random distribution for the condensed silicon centres is indicated by Fig. 6. According to TEM specifications the element detection limit can be as low as 10^{-21} g, which would correspond to about 50 silicon atoms. This means that crosslinking still could be achieved by clusters consisting of about 50 silicon atoms with no detection possible. Therefore, additional investigations are necessary to decide accurately whether this new crosslinking process is favouring more a possible cluster formation or the ideal theoretically predicted structure.

4.2. DSC

Standardized (according to mass) DSC diagrams of the investigated samples are shown in Fig. 7. Melting takes place over a wide temperature range of 10–15 K, indicating that the crystal size distribution is not sharp. When considering the influence of the different chain structures, the melting behaviour of L0, Y0 and S0 has to be studied. These samples do not contain any epoxide silane molecules, and are therefore not crosslinked. It is seen that the melting peak is shifted to lower temperatures as the chain structure becomes more complex. This indicates that a more branched chain structure and therefore shorter linear chain segments can form only smaller and more disturbed crystallites.

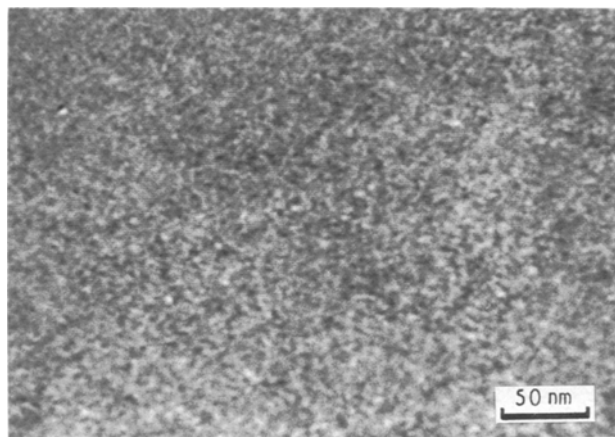

Figure 6 Net element distribution of silicon in S100 ($\Delta E = 99.2$ eV).

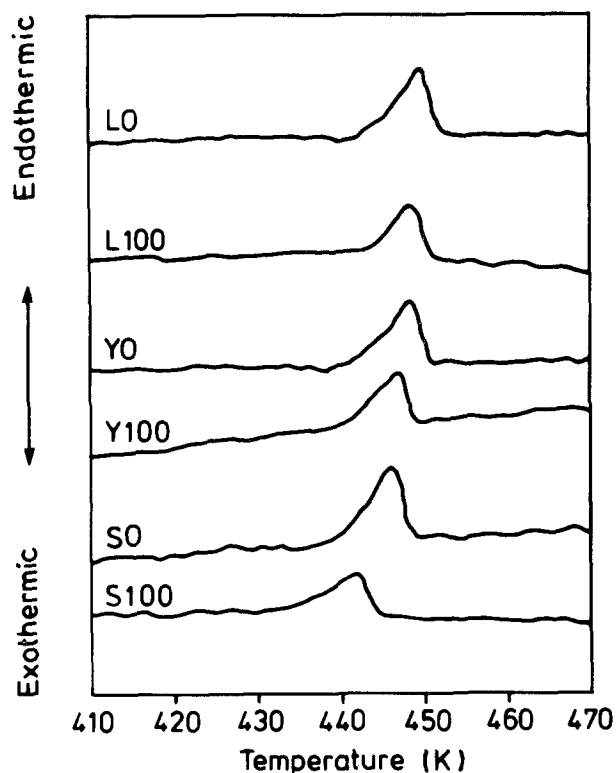

Figure 7 Standardized (according to mass) DSC diagrams of the investigated materials.

The influence of crosslinking can be seen when considering different amounts of epoxide silane on the same chain structure. Comparing the melting peaks of L0 and L100, the L100 peak is shifted to slightly lower temperatures. For the Y-material the melting peak of the crosslinked sample Y100 is clearly shifted to lower temperatures with respect to Y0. For the highly branched S-material the melting peak for the S100 sample occurs at remarkably lower temperatures and is clearly broadened in comparison with S0.

These results indicate that the more highly branched the chain structure is, the stronger the influence of the amount of epoxide silane (i.e. the degree of crosslinking) on the melting behaviour. The crystallite structure becomes more disturbed and smaller crystallites are formed.

In the ideal case crosslinking should take place at the very end of the manufacturing process by storing the samples in water at 60 °C, i.e. after crystallization is finished. Therefore, the melting behaviour of samples with the same chain structure should not depend on the amount of epoxide silane. The experimental results are contrary to this point of view, which can be explained as follows. As it is impossible to achieve a water-free injection moulding and annealing of nylon-12, some of the crosslinking has already occurred. For the L-material such a "pre-crosslinking" causes mostly longer chains, but for the S-material a more network-like structure is formed, being much more restrictive to crystallization than chain lengthening.

5. Conclusion

A new chemical method for crosslinking aliphatic nylon-12 was introduced. Samples with different chain structures and degrees of chemical crosslinking were investigated by TEM and DSC. It was shown that ruthenium tetroxide is an adequate staining agent for these samples. With selective staining it was shown that the semicrystalline structure of nylon-12 consists of three different phases: the crystalline phase, the amorphous phase and an additional phase (the transition region) lying between them.

High-resolution micrographs of stained ultrathin sections showed mostly a long ordered lamellar crystalline structure, except for samples with a highly branched chain structure, in which a more disturbed crystalline phase was outlined. These results could be confirmed by DSC measurements. The melting behaviour is dependent on both the chain structure and the amount of epoxide silane. In addition, DSC measurements indicated a "pre-crosslinking" during injection moulding and annealing.

The thickness of the lamellar crystal (5–7 nm) was at the lower limit of a stable lamellar structure. The width of the transition region was about 2 nm. Both the lamellar thickness and the width of the transition region were shown to be independent of the chain structure and the amount of epoxide silane, i.e. independent of the degree of crosslinking. The condensed silicon centres were randomly distributed with respect to the resolution of the TEM.

References

1. H. F. E. SCHNELL, Dissertation, University of Regensburg (1991).
2. H. F. E. SCHNELL, D. GÖRITZ and E. SCHMID, *J. Mater. Sci.* **26** (1991) 661.
3. D. MONTEZINOS, G. B. WELLS and J. L. BURNS, *J. Polym. Sci., Polym. Lett. Ed.* **23** (1985) 421.
4. W. EGGLE, A. RILK, J. BIHR and M. MENZEL, *Electron Microsc. Soc. Amer. Proc.* **42** (1984) 566.
5. W. EGGLE, D. KURZ and A. RILK, *Mag. Electron Microscopists (Zeiss)* **3** (1984) 4.
6. J. S. TRENT, J. I. SCHEINBEIN and P. R. COUCHMAN, *Macromolecules* **16** (1983) 589.
7. G. KANIG, *Prog. Colloid Polym. Sci.* **57** (1975) 176.
8. M. KUNZ, M. MÖLLER, U.-R. HEINRICH and H.-J. CANTOW, *Makromol. Chem., Macromol. Symp.* **20/21** (1988) 147.
9. B. WUNDERLICH, "Crystal structure, morphology, defects" (Academic Press, New York, 1973).
10. P. J. FLORY, D. Y. YOON and K. A. DILL, *Macromolecules* **17** (1984) 862.
11. L. MANDELKERN, R. G. ALAMO and M. A. KENNEDY, *ibid.* **23** (1990) 4721.

Received 1 May
and accepted 12 September 1991